

## Section 2

# Brakes

### Objective

To ensure that the brakes operate effectively and are correctly adjusted.

### Australian Design Rules relevant to this section

ADR 35	Commercial vehicle brake systems
ADR 42	General safety requirements
ADR 64	Heavy goods vehicles designed for use in road trains and B-doubles

### 2.1 Check brake components

#### Reasons for rejection

- Brake pedals do not have an anti-slip surface across the complete surface
- Brake pedals or handles are broken, missing or are outside the scope of manufacturer's original design
- Brake control mountings, pivots, cables or links are kinked, missing, loose, broken, excessively worn or binding
- Vehicle is not equipped with an effective mechanical park brake

↘ Mechanical park brake refers to the engagement of the brake and not the activation method. Some late model vehicles are equipped with an electric park brake control switch and not a traditional lever. These electronic park brake control switches are considered to comply.

- The locking device on a park brake handle or lever is missing or not operational
- Park brake control is not designed to minimise risk of inadvertent release (e.g. requiring two separate or distinct movements)
- Abrasions or cuts on brake hoses penetrate further than the outer protective covering
- Brake pipes, hoses and connections are not securely mounted, or are cracked, broken, kinked, crimped, damaged by heat, or have visible signs of leakage, swelling or bulging
- Air reservoirs do not have an automatic or manual condensate drain valve at the lowest point of each air brake reservoir

↘ Automatic condensation drain valves must have a means to allow water from the compressed air reserve to be drained manually.

## Section 2 - Brakes

- j. Brake drums or discs are not fitted or have missing pieces, or cracks other than short heat cracks inside the drums or in the disc
- k. Brake pad or shoe material does not come in full contact with brake disc or drum friction surface, excluding any crowning

✎ Brake pad or shoe material should not protrude from the drum by more than 3mm.

- l. Drums or discs are worn beyond manufacturer's specifications
- m. Any calliper, wheel cylinder or master cylinder leaks
- n. Friction material of the linings or pads are contaminated with oil, grease, brake fluid or another substance that will reduce the friction coefficient of the friction material
- o. The thickness of the linings or pads is less than the manufacturer's recommended minimum. If this is not known or is no longer appropriate, the thickness of the linings or pads is less than the following:
  - the rivet or bolt head on riveted or bolted linings or
  - within 3mm of the friction material mounting surface on bonded pads or linings.
- p. Brake chambers (including chamber clamps) or camshaft support brackets are loose, bent, cracked or missing
- q. Air or hydraulic cylinders, hoses or chambers on sliders leak

✎ It is acceptable to have normal weeping of hydraulic seals.

- r. Brake linings or pads are missing, broken or loose on their shoes or plates.
- s. Brake components are mismatched on the same axle i.e. booster size and volume.
- t. Brake components such as springs, anchor pins, cam rollers or bushes, pull or push rods, clevis pins, retainers or brake chamber mounting bolts are missing, loose, damaged or broken.

✎ It is acceptable to have small cracks, blemishes or blisters that do not affect the way the friction materials are attached or its contact with friction surfaces.

- u. Hydraulic or air-over-hydraulic brake system components, such as reservoirs, master cylinders or servo units, are loose, cracked, broken, or excessively worn or are damaged so that leaks are likely.
- v. Vehicles equipped with Antilock Braking Systems (ABS) where the antilock system warning light is inoperative or indicates a system fault or is missing.
- w. Hydraulic or air-over-hydraulic brake system master cylinder reservoir fluid levels are below the minimum level.
- x. There are any air/vacuum or hydraulic leaks.
- y. The brake controls of the towing unit do not cause the corresponding trailer brake to work when they are operated.

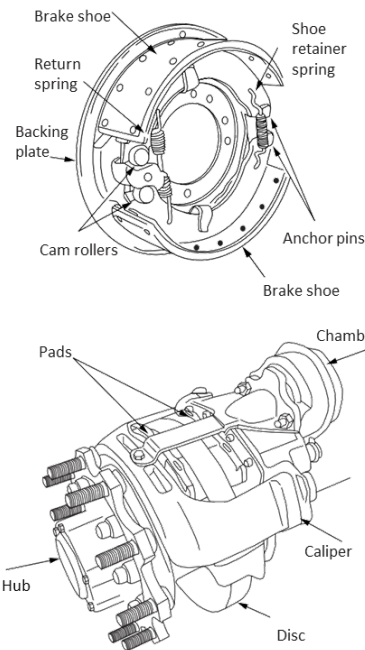
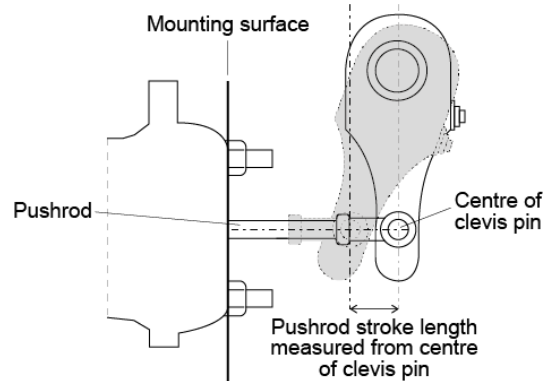

Figure 2.1 Drum and disc brake components

### 2.2. Check brake adjustment

#### Reasons for rejection

- a. With any brake fully applied, a brake adjustment indicator runs out of travel or indicates that adjustment is necessary
- b. Brake chamber push or pull rods move more than the brake component manufacturers recommendation or where this is unavailable, 80% of their maximum stroke when the brakes are fully applied



Figure

#### 2.2 Measuring stroke length

✎ The push or pull rod may travel further on long stroke brake chambers. Further information on long stroke brake chambers can be sought from the brake component manufacturers or industry advisory documents

- c. With any brake fully applied, any stroke indicator displays evidence of excessive stroke (known as over-stroking)

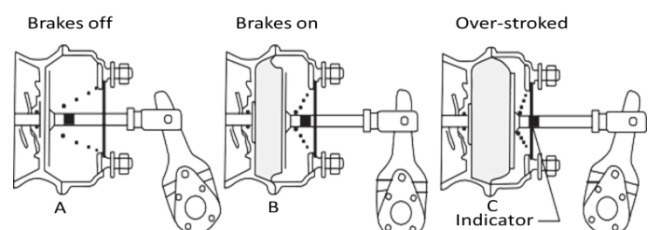

Figure 2.3 Example of excessive stroke/over-stroking

## Section 2 - Brakes

⚠ Not all push and pull rods will have a stroke indicator.

Not all automatic slack adjusters which travel past 90 degrees are considered over-stroked.

Further information on slack adjusters can be sought from the brake component manufacturers or industry advisory documents.

- d. The park brake and/or emergency brake is not capable of being fully applied without the control running out of available travel
- e. The brake adjusters are bent, damaged or excessively worn, or are not properly adjusted.

### 2.3. Check air compressor/vacuum pump

#### Reasons for rejection

- a. The air compressor or vacuum pump has loose mounting bolts, cracked or broken mounting brackets, braces or adaptors, or is inoperative
- b. Drive pulleys are cracked, broken or loose
- c. Drive belts are loose, cracked through to reinforcing plies, extensively frayed or missing drive sections
- d. The air compressor of a compressed air brake system does not build up air pressure to at least 80% of the vehicle's governor cut-out pressure in five minutes after the compressed air reserve is fully used up.

### 2.4. Check air filters

#### Reason for rejection

- a. Any air compressor or vacuum pump filter units are not fitted, or are loose, blocked or damaged.

### 2.5. Check braking system operation

#### Reasons for rejection

- a. Any brake failure indicators do not operate
- b. Any brake air or vacuum storage system is not fitted with a visual or audible warning device to warn the driver, whilst seated in the normal driving position, of a lack of air pressure or vacuum
- c. Any compulsory pressure, vacuum or low level warning devices or gauges do not operate
- d. The brake controls do not cause the corresponding brake to apply when they are operated (with the engine running if necessary).

### 2.6. Check vacuum assisted brake system integrity

#### Reasons for rejection

- a. With vacuum depleted from the system and with moderate steady force applied, the brake pedal does not travel towards the floor when the engine is started
- b. With the engine stopped, one application of the service brake with a moderate pedal force results in the low vacuum indicator coming on
- c. If a trailer can be connected to the motor vehicle, the trailer vacuum brakes cannot be applied from the normal driving position

- d. A brake pedal that is held depressed while the engine is running, tends to rise when the engine is stopped
- e. Vehicle fitted with a vacuum braking system is not fitted with at least one vacuum storage reservoir or tank
- f. The reservoir or tank for vacuum or air storage is not protected by a check valve with manual function
- g. Reservoirs are not secured or their mountings are deteriorated
- h. Vacuum build up time to reach the low vacuum mark (to deactivate the warning device) is longer than 30 seconds from starting engine.
- i. Time taken for vacuum to reach normal working level when the vacuum reserve is fully depleted is longer than 60 seconds
- j. The vacuum warning device (if fitted) does not deactivate when the low vacuum mark is reached
- k. The loss of vacuum from its maximum indicated level exceeds 125mm Hg in 10 minutes when the engine is stopped
- l. With the engine stopped and vacuum at its maximum indicated level, the vacuum gauge reading does not fall progressively with every application of the service brake
- m. With the engine stopped, there is insufficient level of vacuum to allow at least two assisted service brake applications.

### 2.7. Check air brake system integrity (including air over hydraulic)

These checks require the assistance of another person to operate the vehicle controls.

Use chocks to prevent accidental movement of the vehicle.

Observe manufacturer's shut-down instructions before switching off the engine (e.g. to avoid turbo-charger damage).

#### Reasons for rejection

- a. A visual or audible warning device connected to the brake system does not provide a warning to the driver when the air pressure is lowered to less than the following levels, unless the manufacturer specifies a different level:
  - 65% of average operating pressure or
  - 420kPa (60psi) for ADR 35 vehicles, or
  - 300kPa (45psi) for pre-ADR 35 vehicles.
- b. The cut-out pressure is more than 1120kPa (160psi), or less than 720kPa (100psi) unless other values are recommended by the manufacturer
- c. The governor cut-in pressure is less than 550kPa (80psi), unless another value is recommended by the manufacturer
- d. With the brake system fully charged, the engine stopped and the service brake applied, the air brake pressure drops more than 20kPa (3psi) per minute. An additional drop per minute of 5kPa is allowed for each trailer that may be attached
- e. With the engine stopped and the service brake released, the air brake pressure drops more than 15kPa per minute. An additional drop per minute of 5kPa is allowed for each trailer that may be attached
- f. With the brake system fully charged and the engine stopped, five applications of the service brakes result in the reservoir pressure dropping to less than 50% of the maximum value
- g. Spring brakes (if fitted) activate before the low pressure warning device activates

## Section 2 - Brakes

- h. The parking brake is inoperative or on a vehicle with a reserve air tank is unable to be released at least once
- i. Air reservoir drain valves on reservoirs do not work properly cannot be readily operated by the driver/ operator or the valve is not fitted at the lowest point of the reservoir
- j. Air reservoir drain valves are inoperative
- k. Excessive oil drains from the reservoir (this usually indicates a faulty compressor)
- l. Where a pressure protection valve is fitted, the valve is damaged or broken
- m. For a motor vehicle built from 1 July 1998 and designed to tow a trailer, the air supply to the trailer is not automatically stopped when at least one of the prime mover circuits drops below 420kPa or when the trailer is disconnected

⚠ Although it is usually a sign of neglected brake maintenance, excessive water in a reservoir is not a reason for rejection, provided that it is fully drained during the check.

When performing a dynamic emergency brake test, care is to be taken not to damage components (e.g. tail shaft mounted emergency brakes).

- n. Where ADR 35 applies, when the air-pressure in one (and only one) sub-circuit is fully drained any brake connected to the other sub-circuit fails to operate when the service brake is applied
- o. Where ADR 35 applies, spring brakes (if fitted) apply when one sub-circuit is fully drained.

⚠ ADR 35 and UNECE Regulation 13 both require brake tests to be conducted with the engine running.

For certain vehicles spring brakes may apply if the engine is not running and the service brake circuit has been fully depleted of air.

- In a single circuit service brake system, energy to hold off spring brakes is supplied by a separate dedicated reservoir.
- In a dual circuit service brake system, spring brakes are normally held off by residual line pressure. Repeated applications of the service brake will cause the spring brakes to apply, which is acceptable.
- Some vehicles may have an alternative test procedure. If the vehicle fails the procedures outlined here, advice from the manufacturer may be required.

### 2.8. Check hydraulic brake system integrity

#### Reasons for rejection

- a. When a constant force is applied to the brake pedal for 10 seconds:
  - after the initial travel, the service brake pedal travels to the floor, or
  - the brake system failure indicator comes on.
- b. When the service brakes are firmly applied, less than 20% of the pedal travel remains (unless the brake system is designed for greater travel)
- c. When soft pumping makes the brake pedal travel to the floor.

### 2.9. Brake testing

Undertake testing on the motor vehicle service braking systems and emergency braking systems (where applicable) in accordance with at least one of the following methods. Consult

your local authority to determine when a brake test is required and for guidance on which test to perform.

Emergency brakes are required to be fitted to vehicles not built to comply with ADR 35 or vehicles not fitted with dual circuit brakes. An emergency brake means a brake designed to be used if the vehicle's service brake fails

⚠ Generally emergency brakes are found on vehicles built prior to 1980. Park brakes fitted to vehicles with dual circuit braking systems are generally not emergency brakes

Table 2.1 Service brake performance

Type of vehicle	Average		Peak	
	m/s <sup>2</sup>	%g	m/s <sup>2</sup>	%g
GVM exceeding 4 .5 tonnes	2.8	29	4.4	45

Table 2.2 Emergency brake performance

Type of vehicle	Average		Peak	
	m/s <sup>2</sup>	%g	m/s <sup>2</sup>	%g
GVM exceeding 4.5 tonnes	1.1	11	1.5	15

⚠ In Table 2.1 and Table 2.2 'Average' is the average deceleration recorded over the test. This is not an averaging of peak decelerations recorded during the test. 'Peak' is the maximum deceleration recorded during the test.

⚠ The maximum stopping distance in this table is intended to cover a wide range of vehicles including some older vehicles with older braking systems. If a modern vehicle is found to only just comply with the prescribed values then the owner should be informed that the brakes are likely to be in need of maintenance.

For vehicles built before 1930, no service brake performance requirements apply, but the on-road brake test should be conducted to assist in determining whether a brake maintenance problem exists. Such problems should be followed up by visual inspection of the brake components

#### Brake test with a decelerometer

Decelerometer standards should be read in conjunction with the equipment manufacturer's instructions.

On some vehicles with light axle loads, or when testing in wet weather, it might be difficult to obtain a brake test result because of wheel lockup. In these cases the pedal pressure should be reduced to a point where only the minimum specified deceleration rates are achieved.

Set up a suitable decelerometer in the vehicle cabin. Drive the vehicle to a speed of at least 35km/h. If the vehicle has a manual transmission, put the transmission into neutral; automatic transmission vehicles may remain in gear. With hands on the steering wheel, bring the vehicle to a halt as rapidly as possible in a safe manner with one sustained and smooth application of the service brakes.

#### Reasons for rejection

- a. The application of the brakes causes the vehicle to swerve from a straight line path
- b. The service braking system decelerates the vehicle at less than the performance requirement specified in Table 2.1
- c. Individual wheel locking cannot be controlled.

To test the emergency brakes (where applicable) with a decelerometer, install the decelerometer, drive the vehicle to a speed of at least 35km/h. If the vehicle has a manual transmission, put the transmission into neutral; automatic

## Section 2 - Brakes

transmission vehicles may remain in gear. Bring the vehicle to a halt as rapidly as possible in a safe manner with one sustained and smooth application of the emergency brake.

Hand brakes fitted to drive shaft or gearbox are not tested using this method, tests should instead be conducted to manufacturer's specifications.

✎ When performing a dynamic emergency brake test, either in accordance with the above method or the manufacturer's specifications, care is to be taken not to damage components (e.g. tail shaft mounted emergency brakes).

### Reason for rejection

- d. The emergency brake decelerates the vehicle at less than the performance requirement specified in Table 2.2

### Brake testing with a skid plate tester

This section should be read in conjunction with the equipment manufacturer's instructions.

Using a skid plate tester, check the performance of the vehicle's braking system in accordance with the manufacturer's test procedure.

### Reasons for rejection

- e. There is more than 30% difference in the brake performance between the wheels on the same axle
- f. The service braking system decelerates the vehicle at less than the performance requirements specified in Table 2.1
- g. An emergency brake (where fitted) decelerates the vehicle at less than the performance requirements specified in Table 2.2.

✎ When performing a dynamic emergency brake test, either in accordance with the above method or the manufacturer's specifications, care is to be taken not to damage components (e.g. tail shaft mounted emergency brakes).

### Reason for rejection

- h. The emergency brake decelerates the vehicle at less than the performance requirement specified in Table 2.2.

### Brake testing with a roller brake tester

This section should be read in conjunction with the equipment manufacturer's instructions and the National Roller Brake Testing Procedure available from [www.nhvr.gov.au/nrbt](http://www.nhvr.gov.au/nrbt).

Using a roller brake tester, check the performance of the vehicle's braking system in accordance with the manufacturer's test procedure.

Release all brakes, place transmission in neutral (not 'park' for automatic transmission) and slowly apply the service brake until maximum force is attained, or wheel slip occurs.

### Reasons for rejection

- i. There is more than 30% difference in the brake performance between the wheels on the same axle
- j. The service braking system decelerates the vehicle at less than the performance requirements specified in Table 2.1

✎ On some vehicles the brake performance requirement might not be reached as the vehicle will be lifted out of the rollers or lock the wheels. Similarly, it might not be reached if a load proportioning valve is fitted to the axle group. In both cases it is

considered a pass if the brake balance is within the specified limit.

- k. Any parking brake assembly (which includes emergency brakes on applicable vehicles) when applied does not give a reading, or the vehicle does not lift out of the rollers

✎ For park brakes that operate independently of the service brakes, care should be taken when performing roller brake testing. When testing using a brake roller is not possible, the parking brake should be tested in accordance with the manufacturer's testing procedures.

### Brake testing using stopping distance method

Test the vehicle's service brake system on a suitable level area with a hard level surface. It is to be free from gravel or loose material and is at least 350 meters in length for testing of heavy vehicles. Drive the vehicle to 35km/h then put the transmission into neutral; automatic transmission vehicles may remain in gear. With both hands on the steering wheel bring the vehicle to a halt as rapidly as possible in a safe manner with one sustained and smooth application of the service brakes.

### Reasons for rejection

- l. The application of the brakes causes the vehicle to swerve from a straight line path
- m. For vehicles built after 1930, the service braking system fails to bring the vehicle to a stop within the distance specified in Table 2.3.

Table 2.3 Service brake stopping distance

Type of vehicle	Distance
GVM exceeding 4.5 tonnes	16.5 metres

Test the vehicle's emergency brake (where applicable) on a suitable level area with a hard level surface. It is to be free from gravel or loose material and is at least 350 meters in length for testing of heavy vehicles. Drive the vehicle to 35km/h then put the transmission into neutral; automatic transmission vehicles may remain in gear. With both hands on the steering wheel bring the vehicle to a halt as rapidly as possible in a safe manner with one sustained and smooth application of the service brakes.

Hand brakes fitted to drive shaft or gearbox are not tested using this method, tests should instead be conducted to manufacturer's specifications.

✎ When performing a dynamic emergency brake test, either in accordance with the above method or the manufacturer's specifications, care is to be taken not to damage components (e.g. tail shaft mounted emergency brakes).

- n. The application of the brakes causes the vehicle to swerve from a straight line path
- o. For vehicles built after 1930, the service braking system fails to bring the vehicle to a stop within the distance specified in Table 2.4.

Table 2.4 Emergency brake stopping distance

Type of vehicle	Distance
GVM exceeding 4.5 tonnes	40.5 metres

- p. The application of the brakes causes the vehicle to swerve from a straight line path
- q. The service braking system decelerates the vehicle at less than the performance requirement specified in Table 2.1

## Section 2 - Brakes

r. Individual wheel locking cannot be controlled.

### 2.10. Parking brake test for vehicle designed to ADR 35

Parking brake test for vehicles designed to ADR 35 or vehicles fitted with tandem master cylinder/dual circuit brakes.

Apply the park brake and attempt to drive forward using a light throttle.

📌 A parking brake means the brake usually used to keep a vehicle stationary while the vehicle is parked.

#### Reason for rejection

a. The parking brake does not provide any retardation.

### 2.11. Advanced Braking Systems

This section covers vehicles which have advanced braking systems such as anti-lock braking systems (ABS), electronic braking systems (EBS), electronic stability control (ESC), etc.

#### Reasons for rejection

- a. An advanced braking system warning lamp:
  - is missing
  - does not illuminate as required when ignition is switched to the on position
  - indicates a fault with a system
- b. An advanced braking system component (wheel speed sensor, etc) is missing, damaged or substituted (e.g. manual slack adjuster in lieu of auto slack adjuster) to an extent where it does not perform its intended function.
- c. Advanced braking system wiring or connectors are corroded, damaged, not insulated or are not securely fastened.
- d. Electrical wiring is located where it can:
  - become exposed to excessive heat
  - come into contact with moving part
- e. An advanced braking system component or system has been modified outside of manufacturer's specifications.
- f. A truck fitted with an advanced braking system is not fitted with a compliant ABS/EBS connector to attach an ABS/EBS equipped trailer (all models 2015 and later).